

品名: 介质滤波器

产品型号: CMF54C1995C30E

1、电气性能 ELECTRICAL SPECIFICATION

序号 NO.	项目 ITEM	规格 SPEC	单位 UNIT
1	中心频率Center Frequency [fo]	1995MHz	MHz
2	带宽 Bandwidth [BW]	≥30MHz	MHz
3	带内损耗 Insertion Loss in BW	≤1.5dB	dB
4	带内波动 Ripple in BW	1.0	dB
5	带内驻波VSWR in BW	≤1.5	dB
6	带外抑制 Attenuation[Absolute Value]	≥30dBc@2170~2200MHz(全温) ≥30dBc@2foMHz ≥30dBc@2491.75MHz ≥30dBc@1207.14MHz	dBc
7	输入功率Input/Out Power	4	W
8	输入/输出阻抗In/Out Impedance	50	Ω

2、外形尺寸 DIMENSIONS

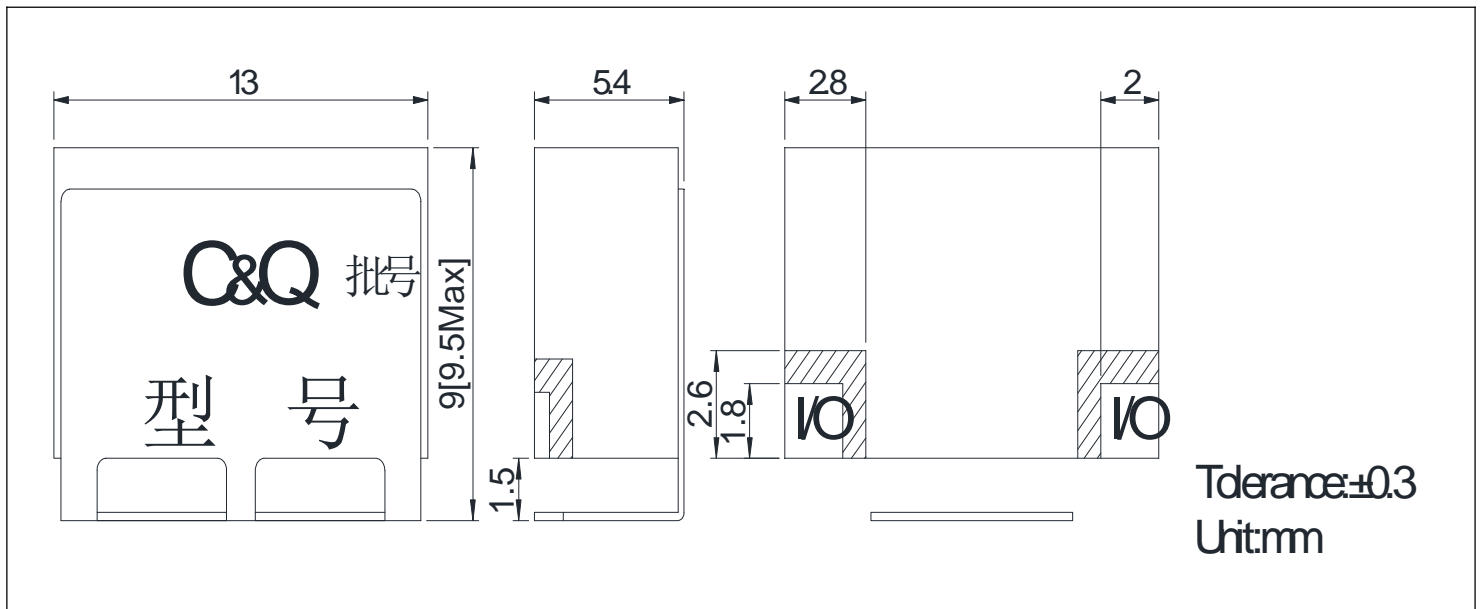

3、推荐焊装 RECOMMENDED PC BOARD PATTERN

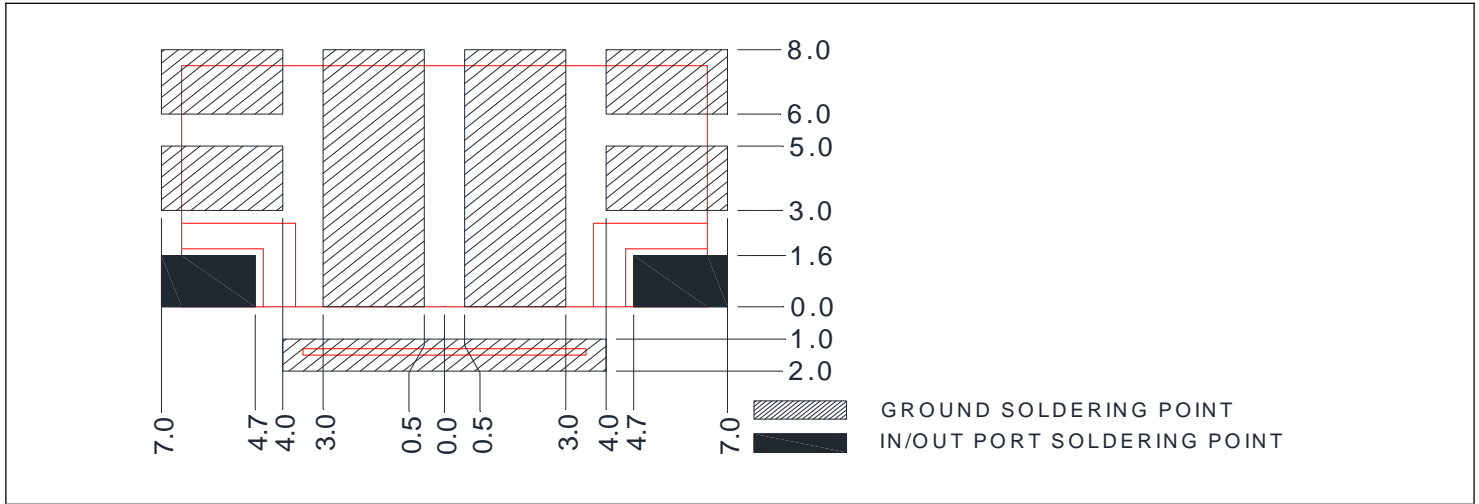

4、环境特性 ENVIRONMENTAL CHARACTERISTIC

序号 No.	项目 ITEM	描述 DESCRIPTION
1	工作温度	-55℃ to +85℃
2	存储温度	-55℃ to +85℃
3	RoHS & WEEE	RoHS

5、回流焊温度推荐 REFLOW SOLDERING STANDARD CONDITION

